

3014 STATIC ELIMINATOR

The 3014 introduces new standards in performance and size in a 24 V DC static eliminator. It offers market leading performance in a very compact bar.

The 3014 offers all of the performance and control benefits of 24 V DC technology in a compact and inexpensive design.

PERFORMANCE

- 7.5 kV of ionising power.
- 20 mm emitter pitch for intense ionisation.
- Unique field overlap technology for enhanced performance.
- Operating distance: 20 - 150 mm.

ESSENTIAL QUALITIES

- Fully encapsulated electronics.
- Tungsten emitters guarantee an unlimited life.
- Shockless operation.
- 24 V DC operation.

CONNECTIVITY AND CONTROL

- LED indication of operational status of bar and whether it needs cleaning.
- Duplicate remote signals for PLC or to power external lamps, relays.
- Remote on/off switching.

APPLICATIONS

- The 3014 was designed to be a high technology replacement for traditional short range AC static eliminator bars. It is used throughout industry.



SPECIFICATION

Construction:

FR-ABS industrial grade extrusion, epoxy resin, tungsten emitters.

Output Voltage:

Up to 7.5 kV supply integrated into bar.

Remote Monitor / Local Status Indication:

Signals available: 'Bar OK', 'Clean Me' and 'Fault'. Compatible with IEC 61131-2 Type 1 and Type 3 PLC inputs. Signal protected against shorting and miswiring. Bi-colour LED on endcap for local status indication.

Electrical Input:

24 V DC (21-28 V), max current 0.5 A. M8 x 4-pin connector. M8 x 4 core cable to be ordered separately.

Environmental:

0 - 55 °C, 70 % rH non-condensing max. IP67. Fully sealed.

Certification:

CE, CB and UL.

Options:

100 - 250 V AC-DC 24 V Power Supply (Part No: E3024-PSU).
Air Knife mounted - see 5000/5100 and 5500.
Air Bar mounted.

DIMENSIONS AND CONSTRUCTION

Dimensions: Profile 20 x 32.5 mm (WxH). Available lengths: 250 mm then in 40 mm steps to 4010 mm. Active length = 20 mm less than overall length.

Weight: 0.25 m = 0.28 kg then 0.51 kg per additional metre.

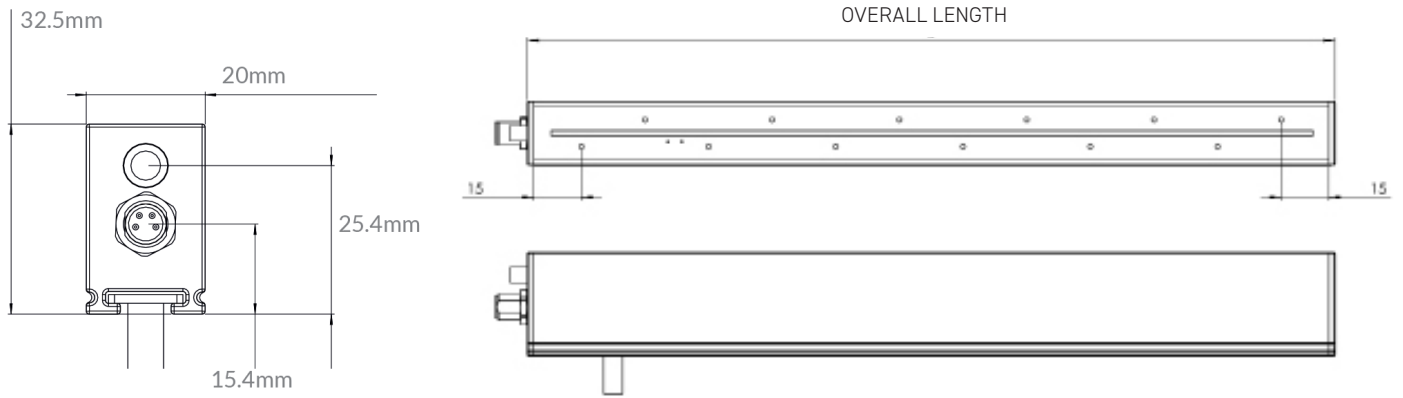

Note: Overall length = order length + 4 mm (including endcaps).

MOUNTING

Each 'T' fixing has one M6 x 40 mm stud and flange nut.

Two 'T' fixings are supplied for bars up to 1000 mm, plus 1 extra for every additional 500 mm.

Other stud lengths are available, contact the manufacturer for details.

The 'T' fixings slide into the slot in the bottom of the bar.

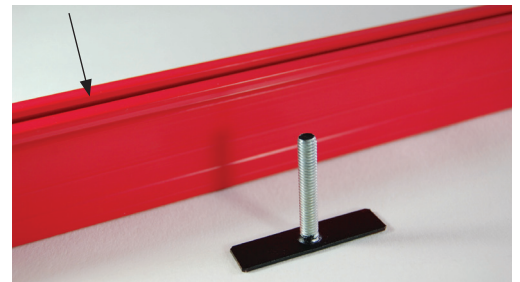

ACCESSORIES AND SPARES

Description	Part No.
3m cable with 180° connector	80892
5m cable with 180° connector	80930
7.5m cable with 180° connector	80931
10m cable with 180° connector	80932
Additional Mounting Set	30248

Description	Part No.
3m cable with 90° connector	80933
5m cable with 90° connector	80934
7.5m cable with 90° connector	80935
10m cable with 90° connector	80936
Universal AC-DC power supply*: 100 - 250 V AC, 24 V DC output fitted with 1.5 m of cable	E3024-PSU

Cables must be ordered separately in addition to the bar. They have standard M8 4-pin female connectors.

* Do not use ANY other standard power supplies with this product. Third party power supplies WILL cause damage and void warranty.